

38 took exam

Printed Name KEY - 345 - 5/6/05 Seat # \_\_\_\_\_

Note! DO NOT set your papers on the seat next to you. If I walk by and see any papers in the seat next to you they will be confiscated. Please take this seriously, because you will have to redo those pages. Just put them under your current work. Many of these problems use the same figures, so label your problem solution numbers carefully. This exam is open book, open notes, open old exams, open homework. The word quantitative means give me numbers. The word qualitative means give me a sketch with relative deflections, but no numbers. Unless the problem gives values, you may leave your answers in terms of A, E, I, etc.

Problem 1) For each of the structures shown in Figure 1, state the degree of statical indeterminacy for solution by flexibility methods.

Problem 2) Draw a released or primary structure amenable to solution by flexibility methods for the structure shown in Figure 1b only. Carefully mark and label your choice of unknowns.

Problem 3) For each of the structures shown in Figure 1, determine the degree of kinematic indeterminacy for solution by stiffness methods, assuming that axial effects are to be excluded.

Problem 4) For the structures shown in Figure 1, determine the degree of kinematic indeterminacy for solution by stiffness methods, assuming that axial effects are to be included.

Problem 5) Draw a restrained or primary structure amenable to solution by stiffness methods for the structure shown in Figure 1b only, assuming that axial effects are to be excluded. Carefully draw and label your choice of unknowns.

Problem 6) For the beam shown in Figure 2, draw 2 quantitative influence lines (i.e. list all values), one for the reaction at "e", and a second for the moment at point "b".

Problem 7) For the statically indeterminate beam shown in Figure 3, draw a careful and accurate qualitative influence line for the reaction at e.

Problem 8) For the frame in Figure 1d, draw a qualitative influence line for the axial load in column BC.

Problem 9) For the loading shown in Figure 4, and given the moment influence line for point B shown, determine the maximum possible negative moment at B. The truck can travel in either direction.

Problem 10) For the beam shown in Figure 5, solve for the rotational deflection at point B using Virtual Work. You may either use Volume Integrals or integration. Use  $E = I = 1$ .

Problem 11) For the structure shown in Figure 6, calculate  $\delta_{11}$  for use in a flexibility solution. The structure is 10 feet wide, and 20 feet tall.

Problem 12) For the structure shown in Figure 7, calculate the stiffness coefficient  $K_{22}$  for use in a stiffness solution. The structure is 10 feet wide, and 20 feet tall.

Problem 13) Using the method of slope deflection, set up the solution to solve for the deflection of the right end of the beam loaded as shown in Figure 8. You need not attempt to solve the final set of equations, but you must calculate all values which go into the slope deflection equations, and write them as a set of equations to be solved.

Problem 14) In your own words, tell me how to do the following. You do not need to write a book. Just briefly tell me enough to know that you have run this program. I better be able to read this!

- In VA, you must input loads onto the members and joints. What step must you first perform before you can put any loads on the structure?
- How do you add new members to your existing structure?
- How do you release the end moments on one end of a member?
- How do you make one of the nodes into a support?

Problem 15) For the structure shown in Figure 9, the length of each member is 12 feet, the load  $P = 20$  kips, and the load is centered on the beam. Calculate an approximate value for the moment on the left end of the loaded beam. Moments of inertia of all members are listed in the figure. Carefully explain to me your reasoning as to what you did. I better be able to read this!

"First I started with \_\_\_\_\_.

Then because \_\_\_\_\_,

I \_\_\_\_\_.

Finally, \_\_\_\_\_

I \_\_\_\_\_."

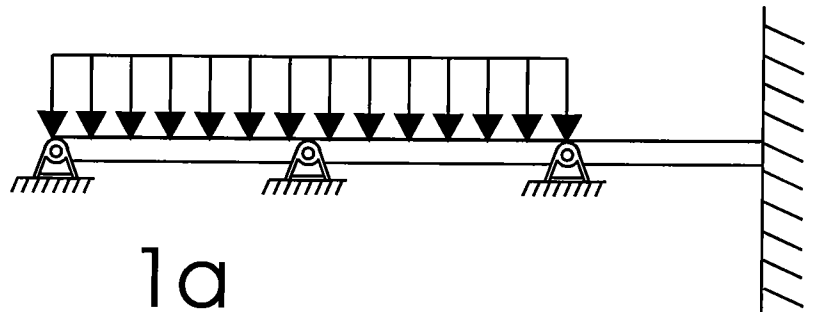

1a

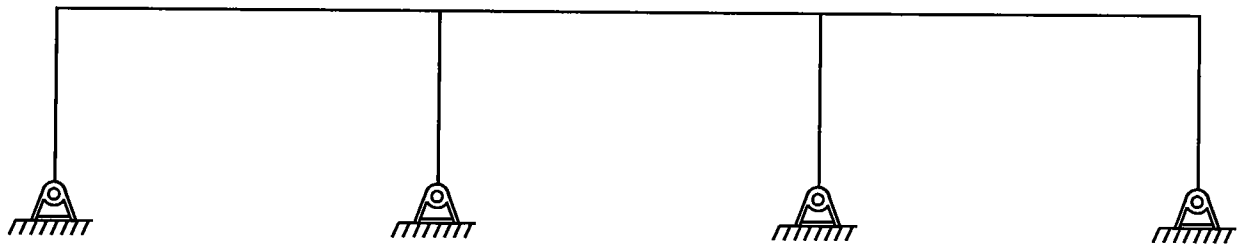

1b

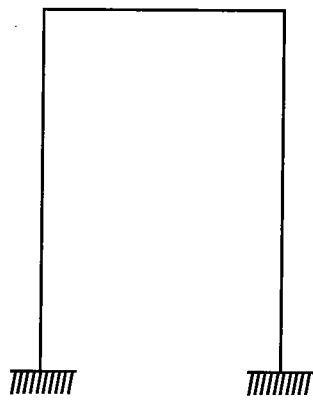

1c

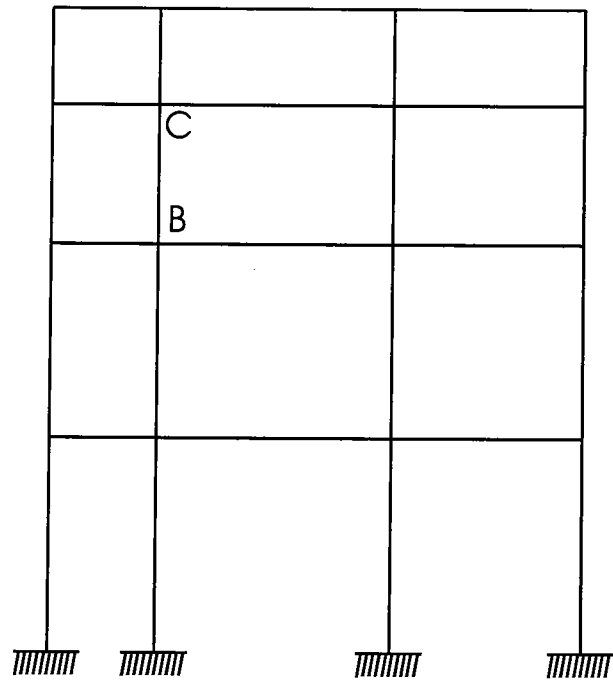

1d

Figure 1

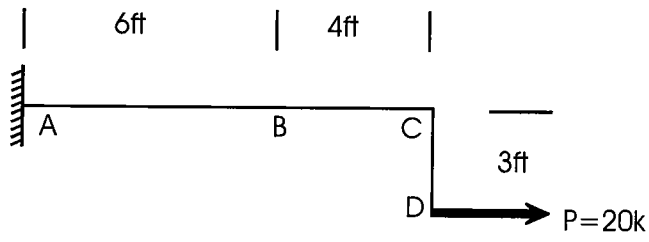

Figure 5

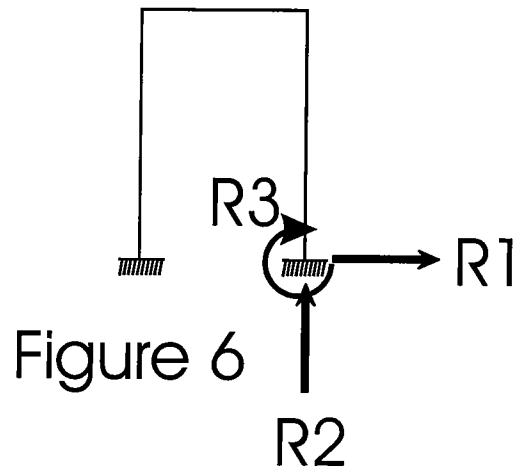

Figure 6

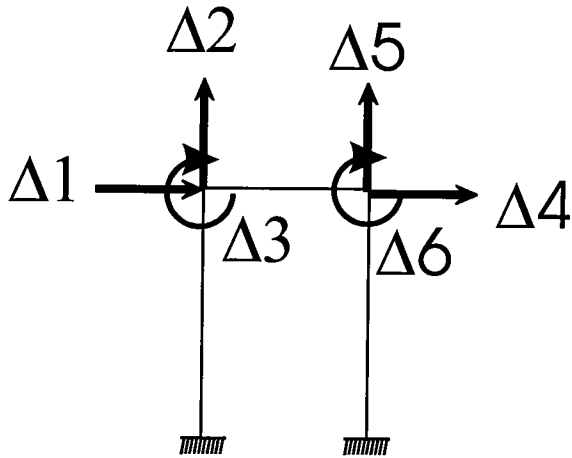

Figure 7

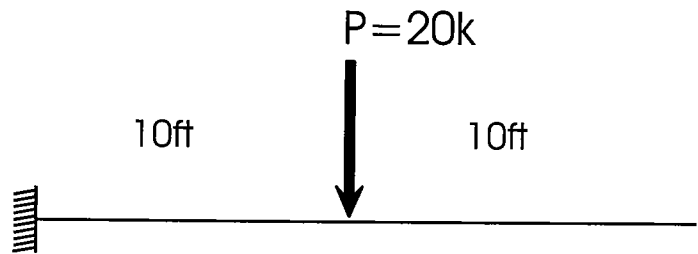

Figure 8

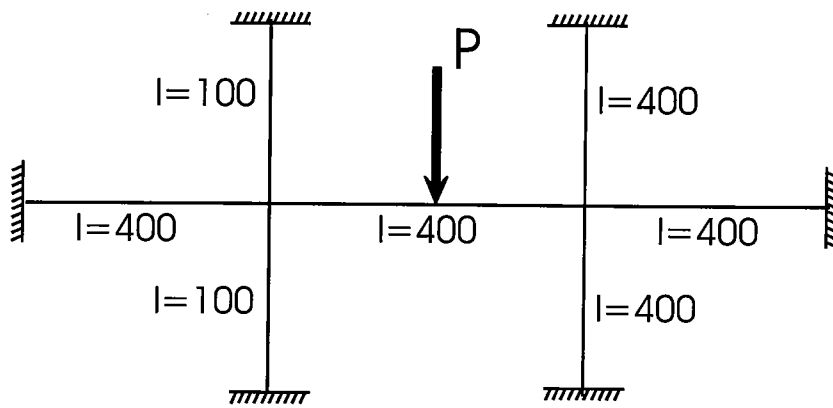

Figure 9

Prob 1

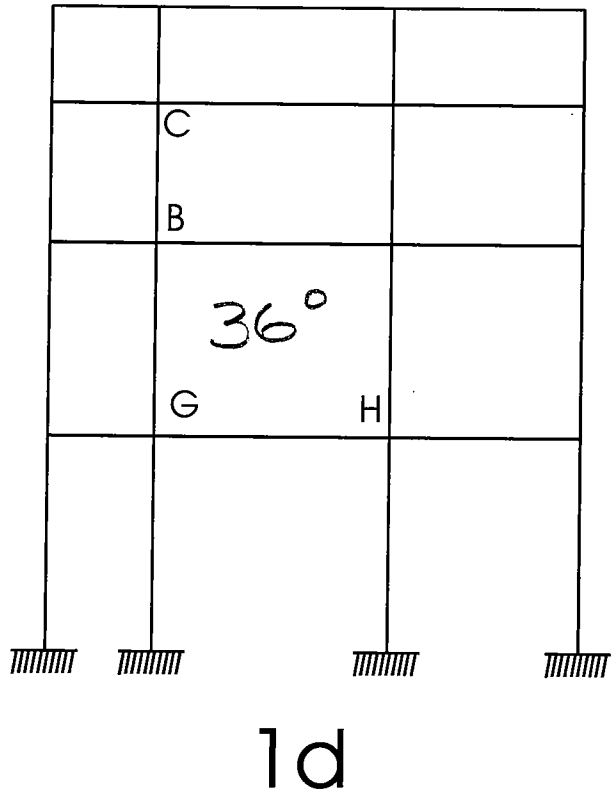
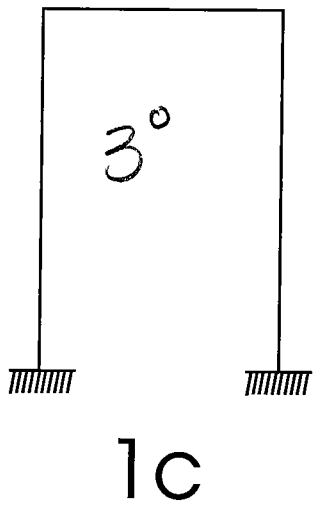
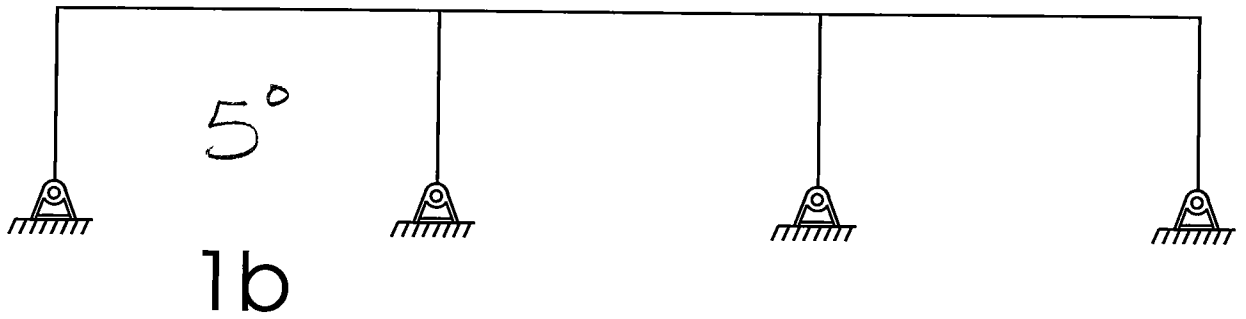
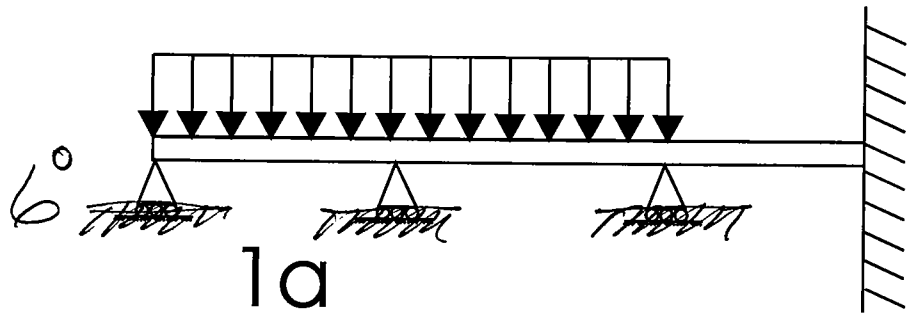
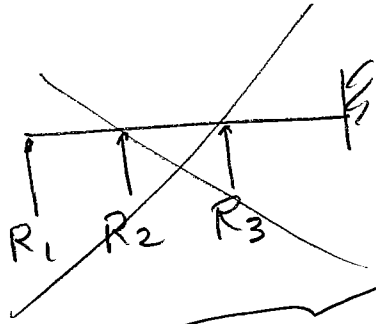
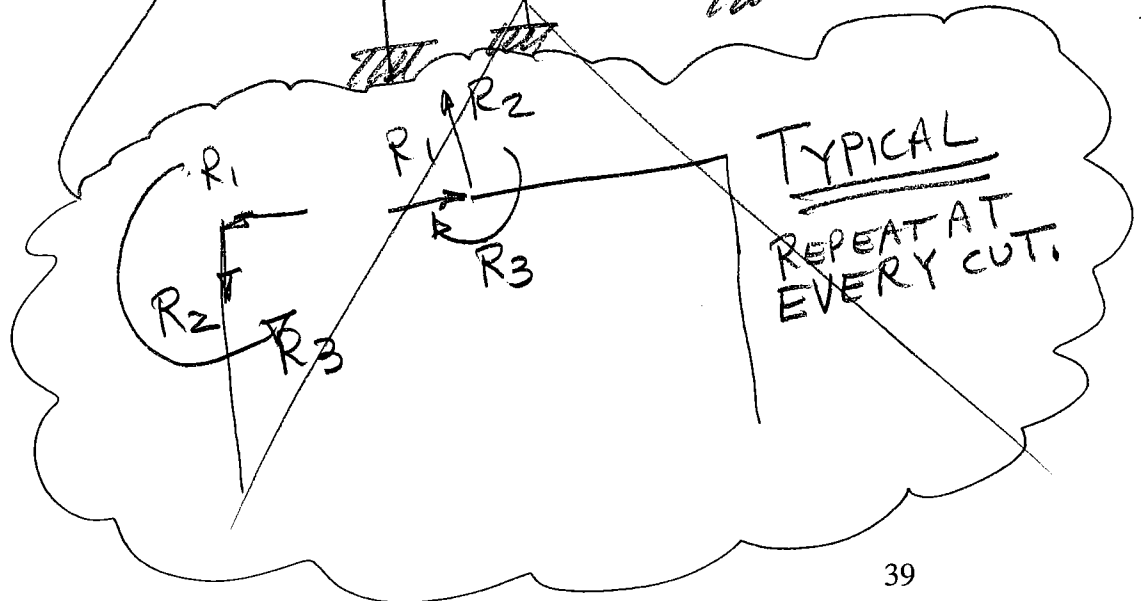
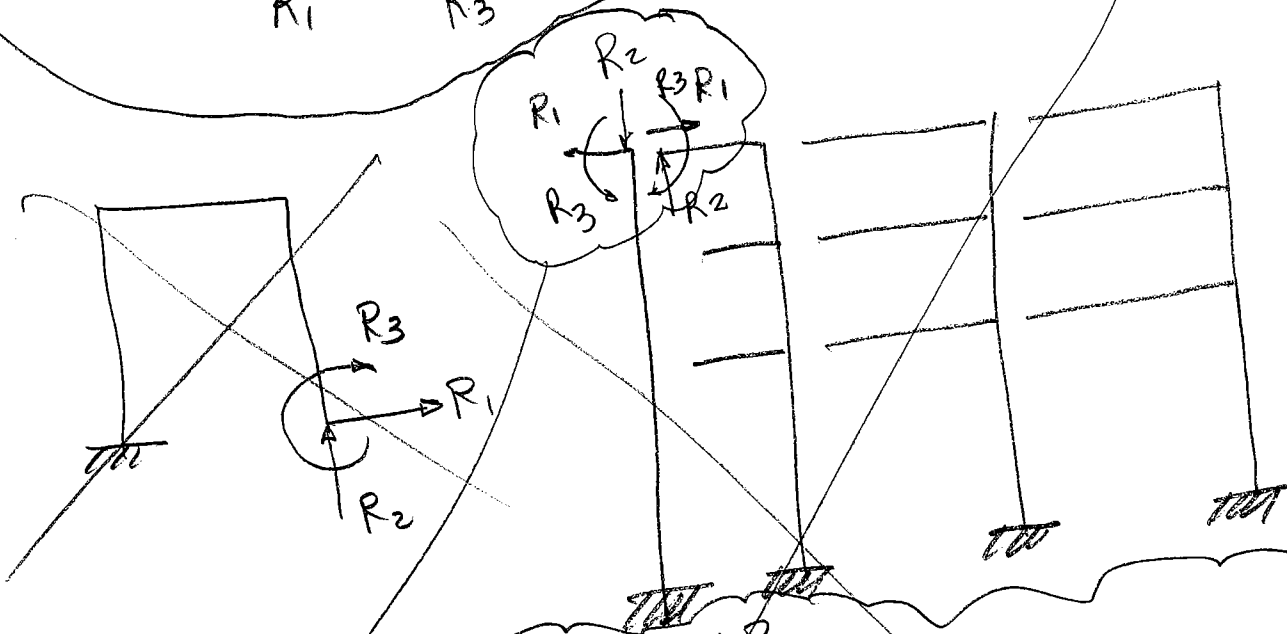
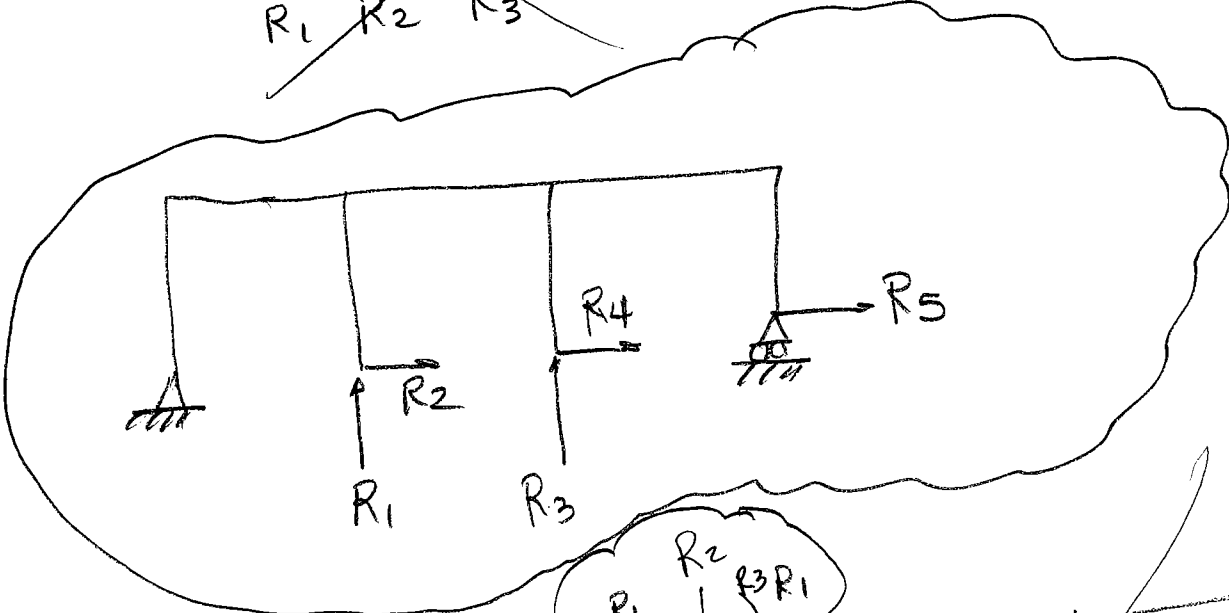

Figure 1

PROB 2



Prob 2b



PROB 3

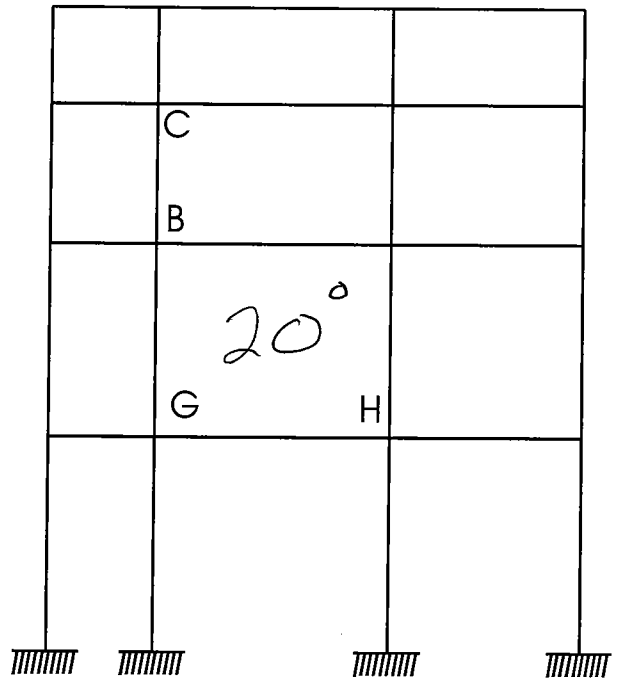
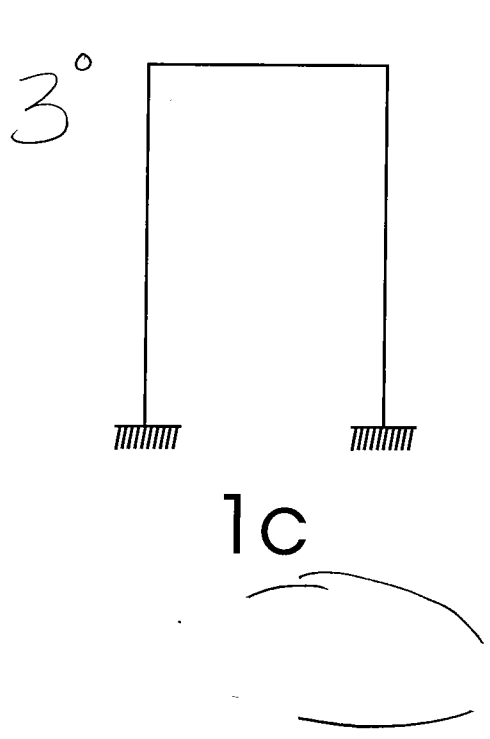
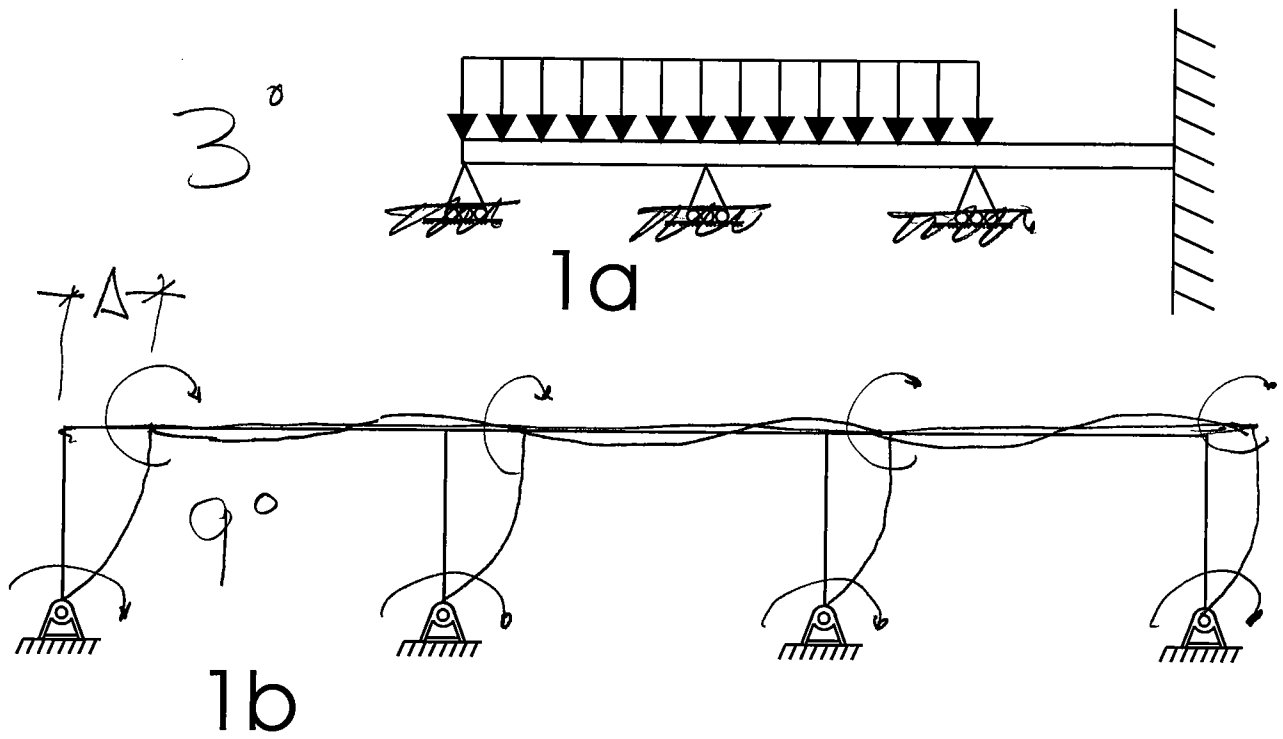

Figure 1

1d

PROB 4

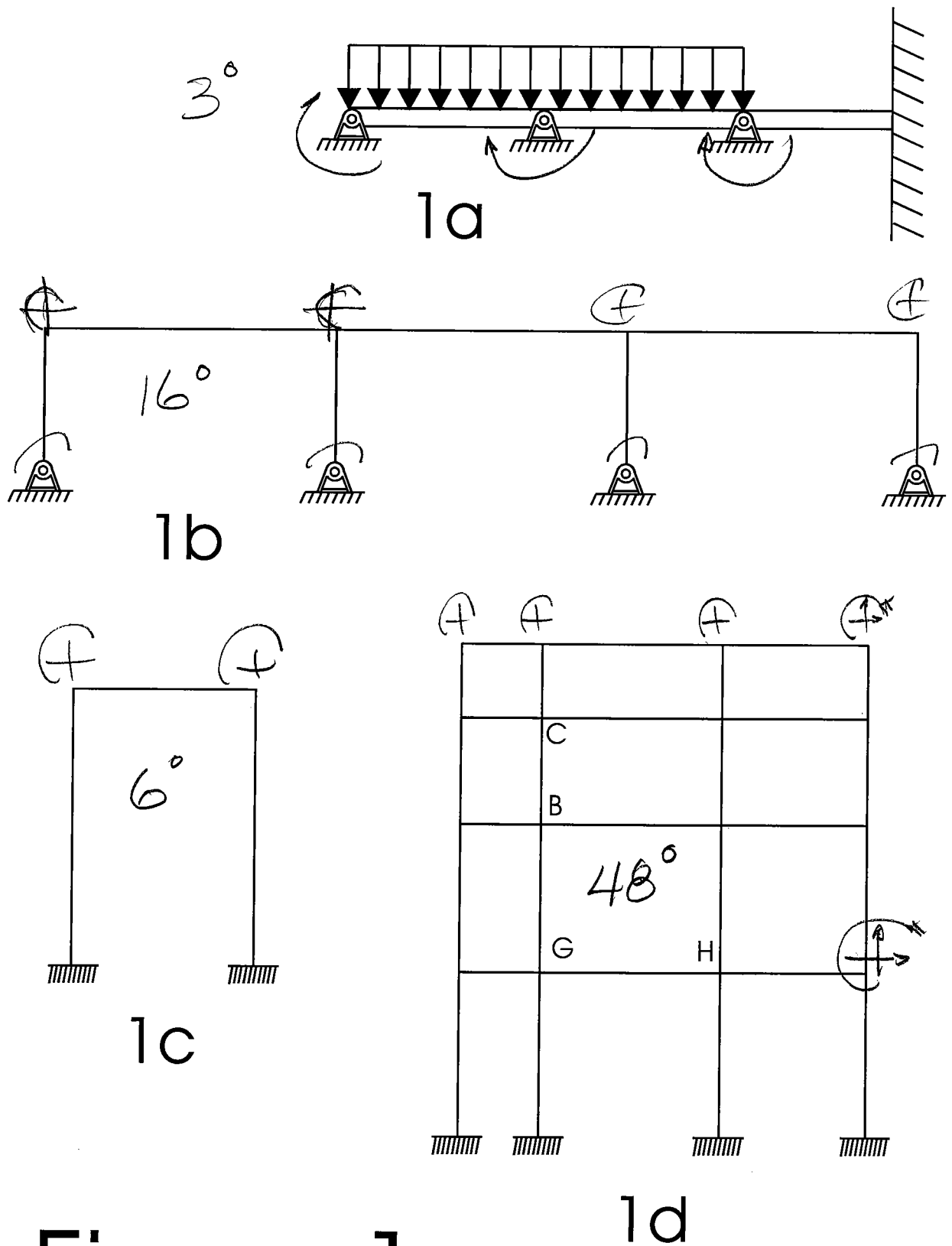
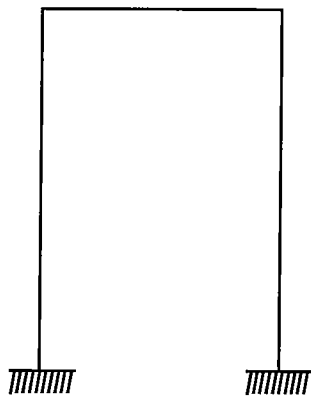
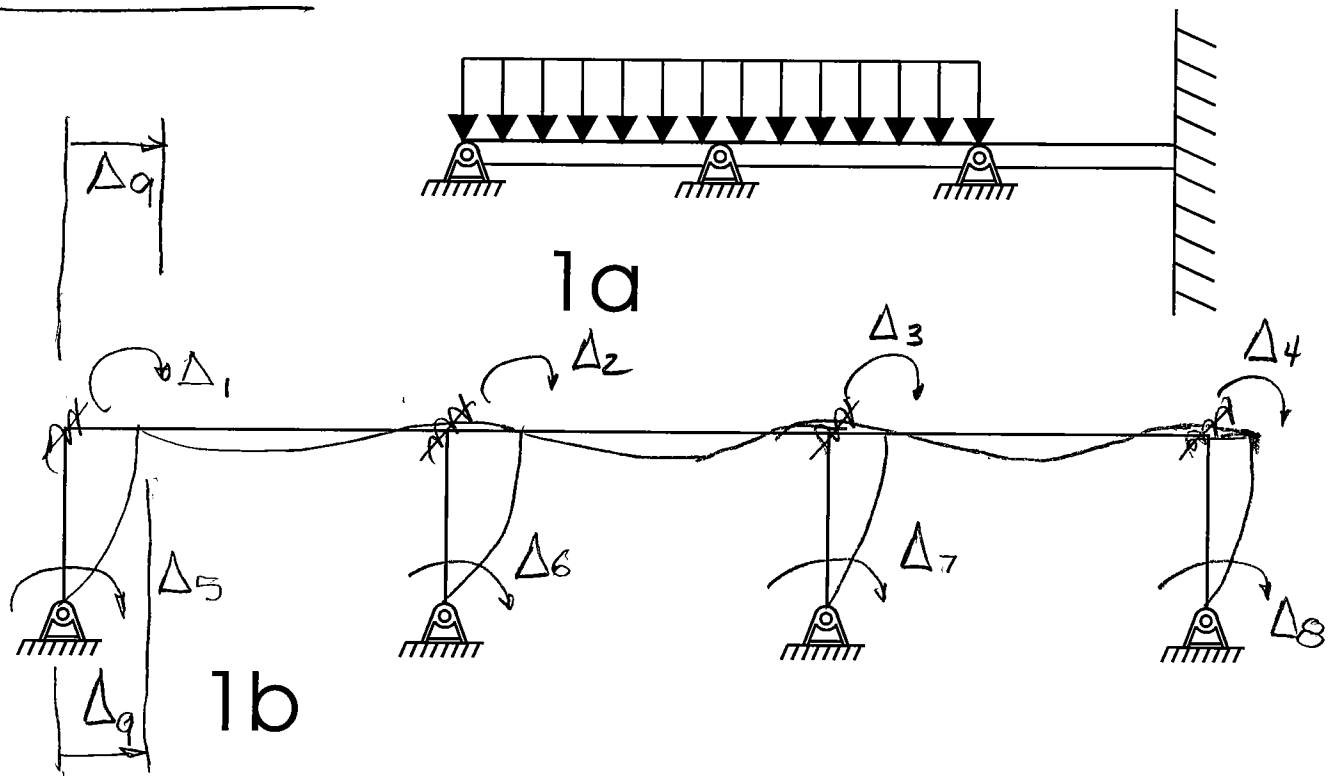
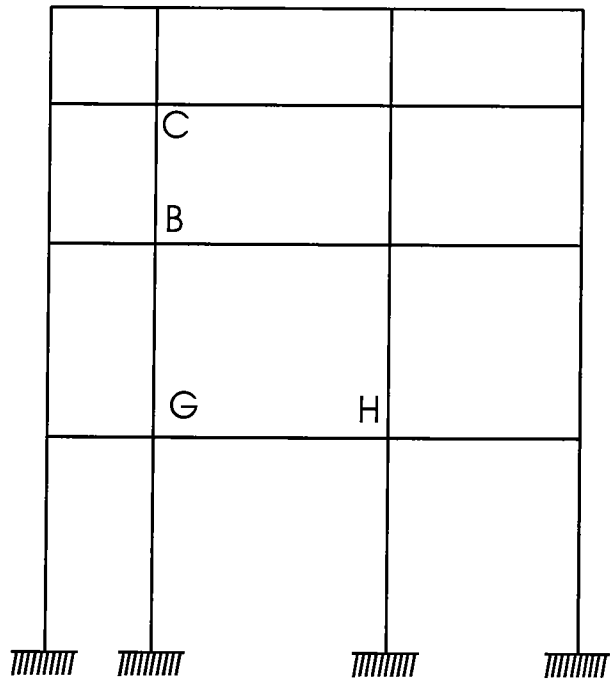

Figure 1

# PROBLEM 5



1c



1d

Figure 1

Prob 6a

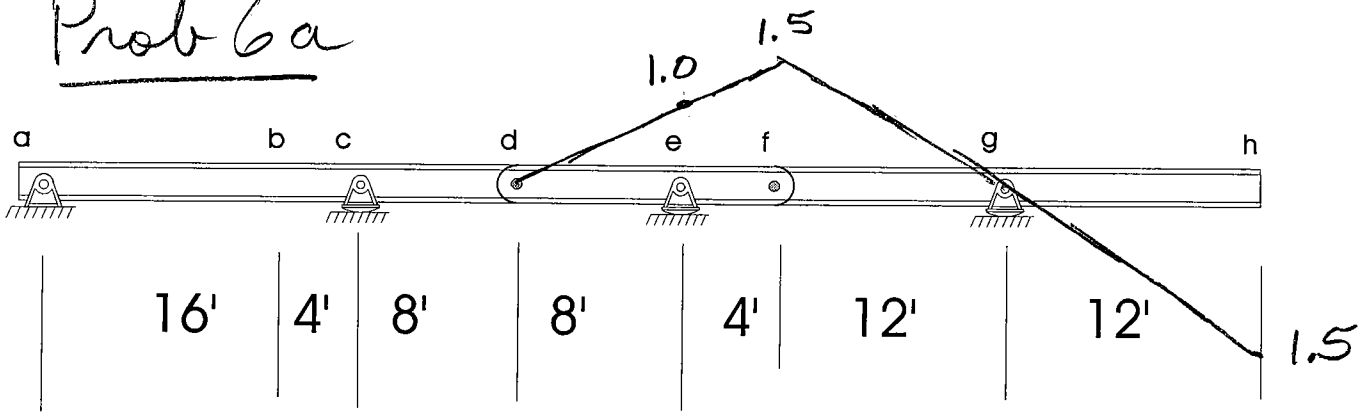

Figure 2

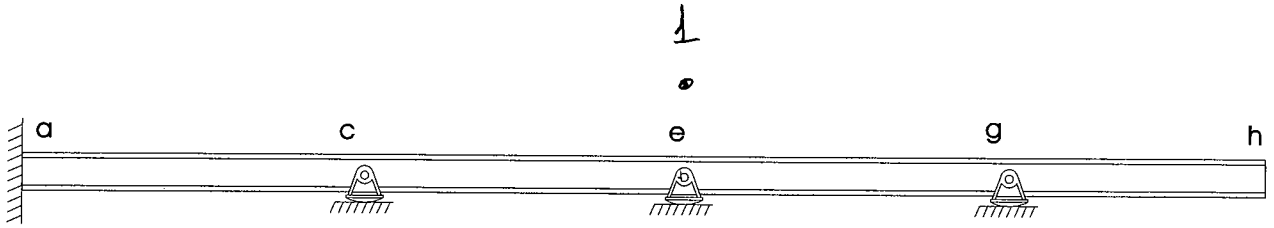

Figure 3

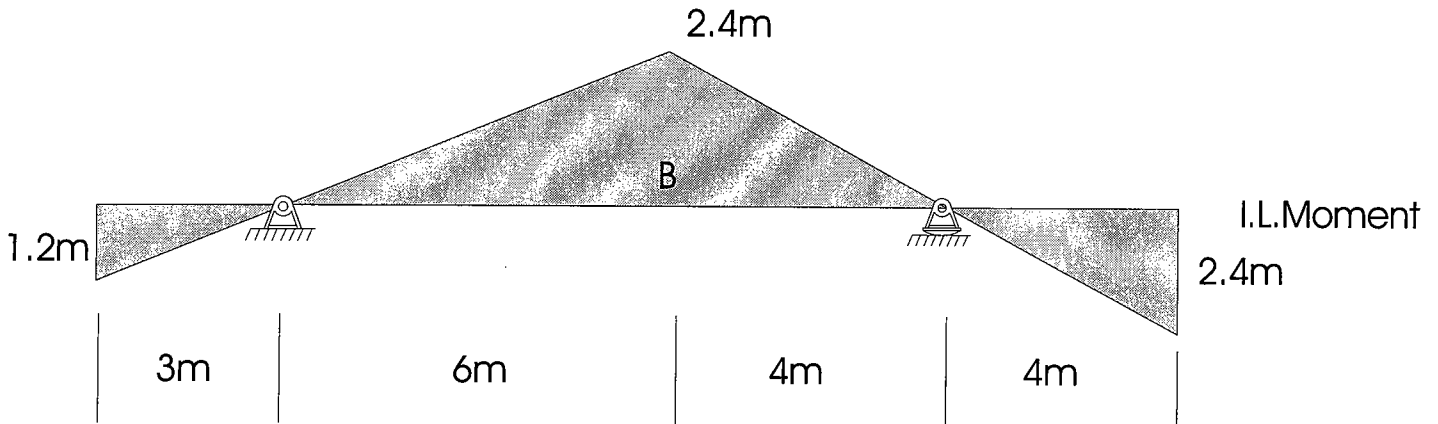
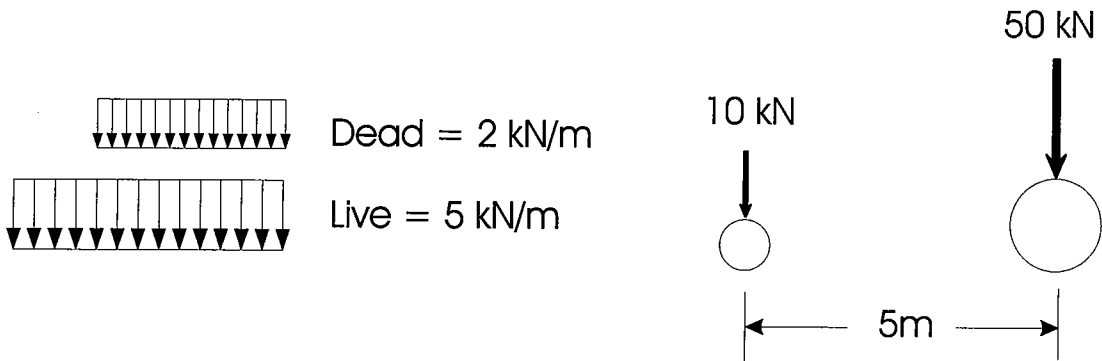

Figure 4

PROB 6b

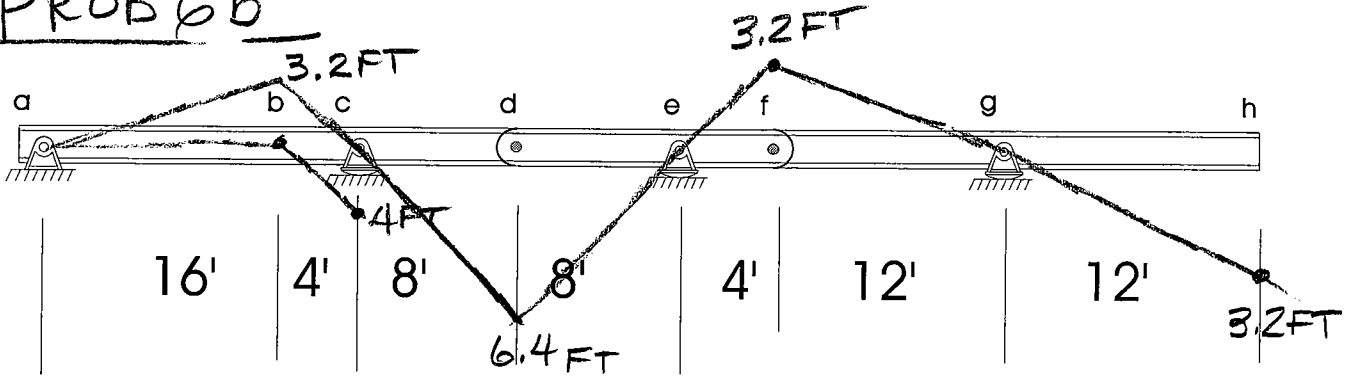

Figure 2

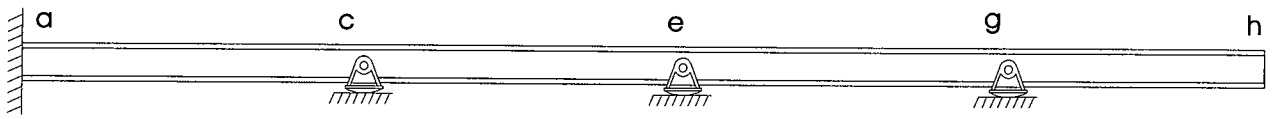

Figure 3

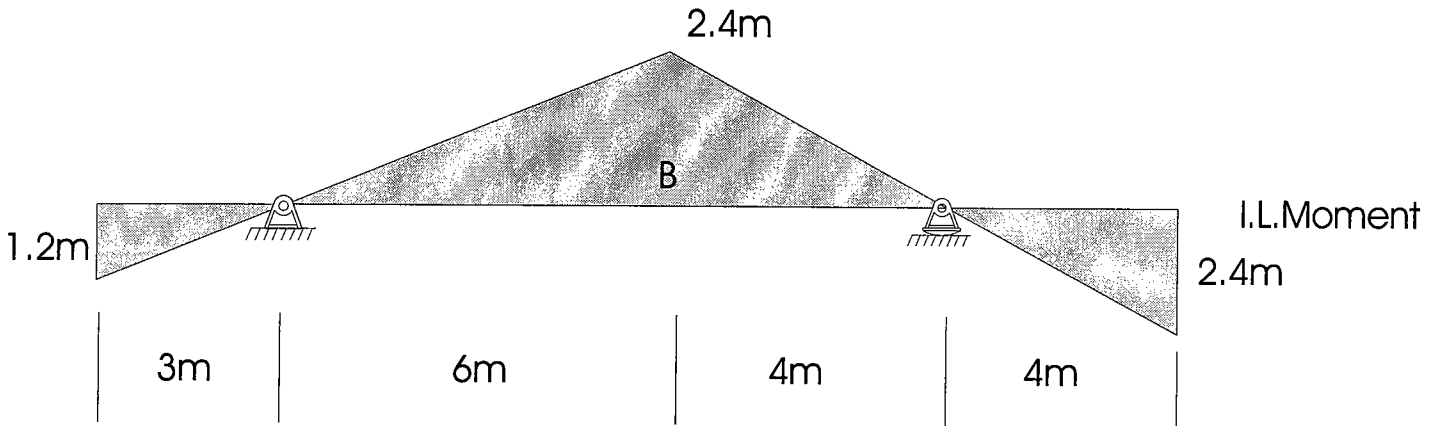
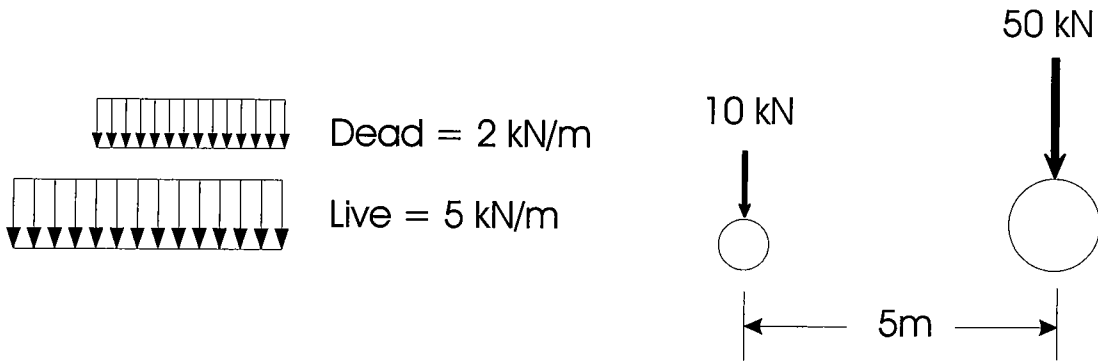

Figure 4

PROB 7

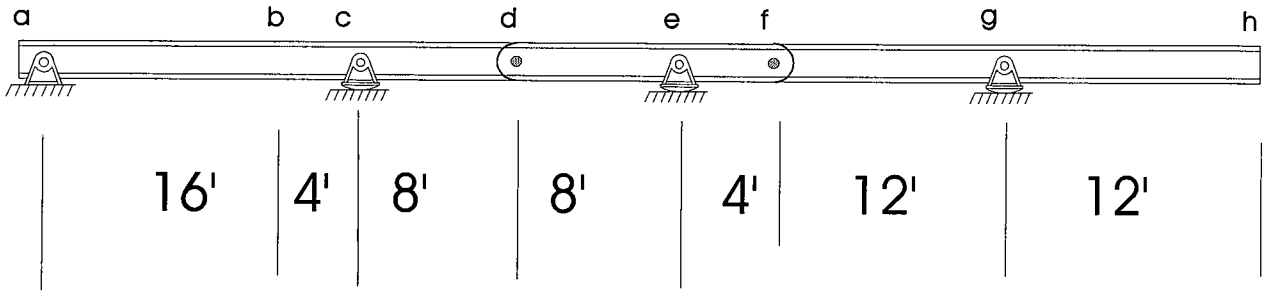

Figure 2

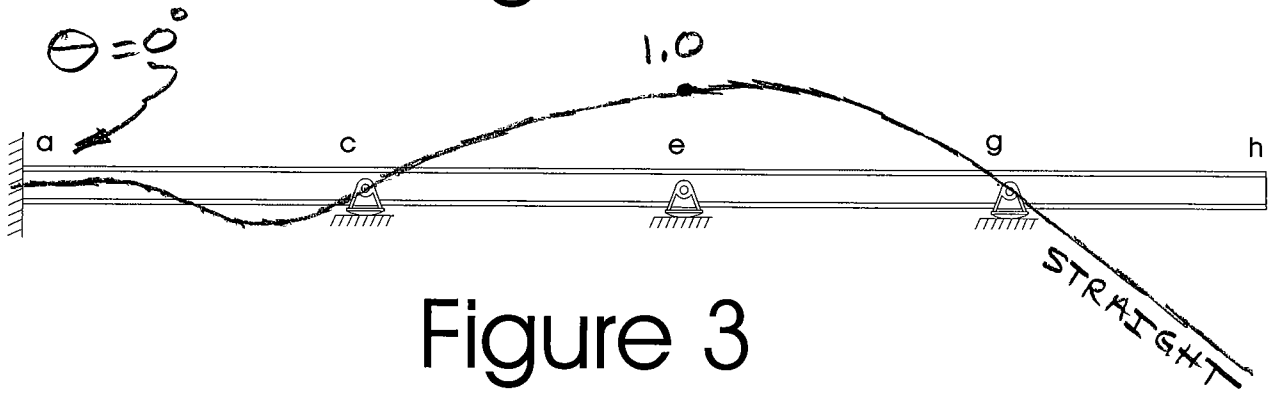

Figure 3

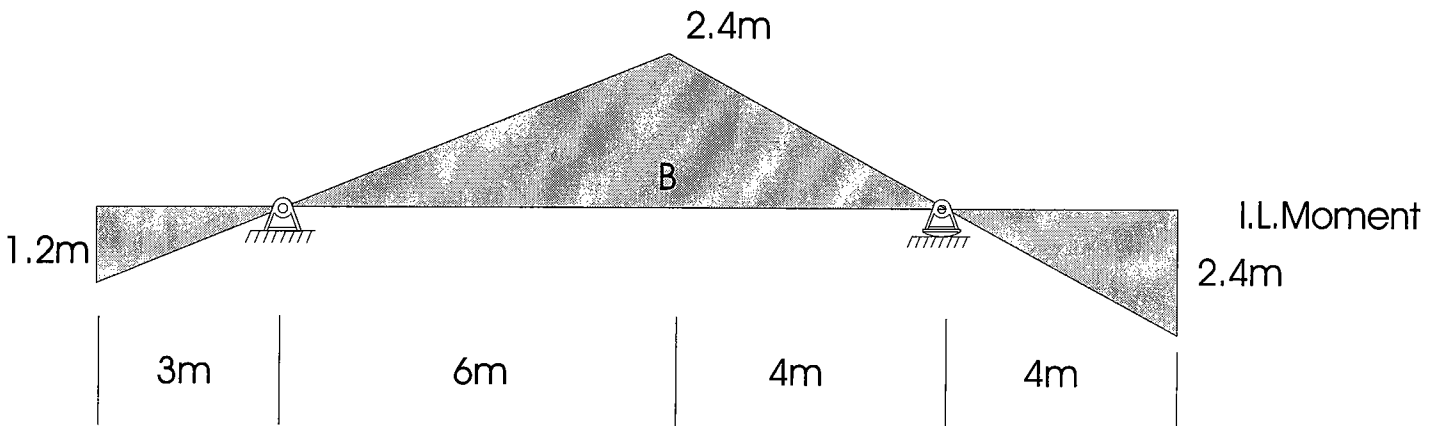
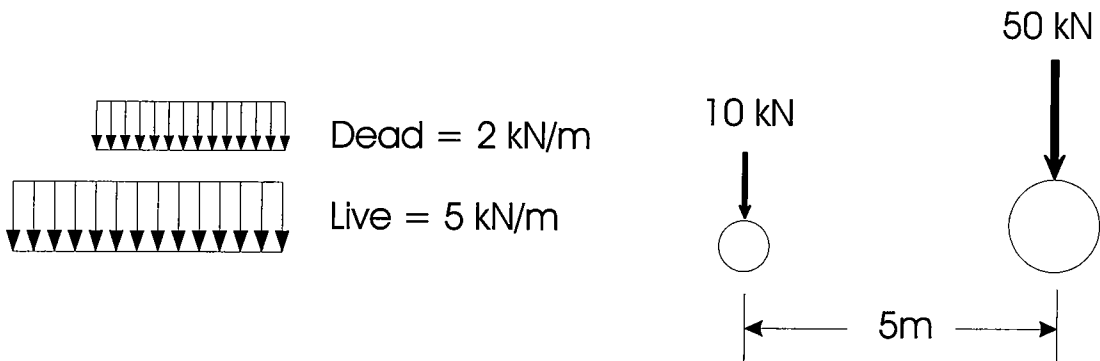
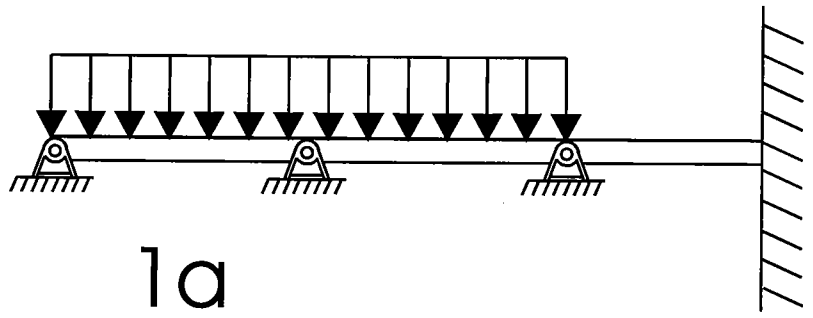
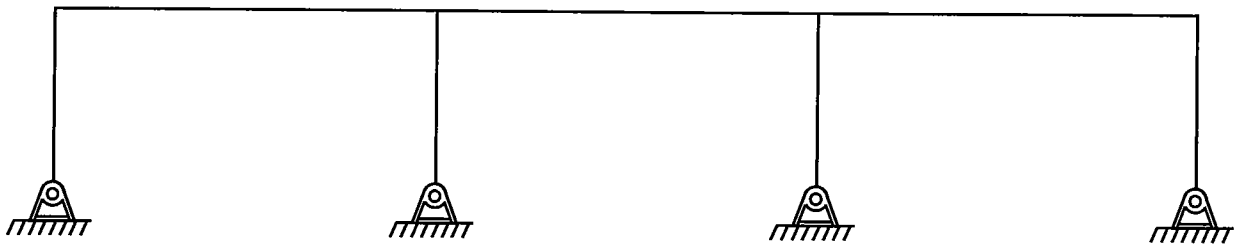

Figure 4

PROBE



1a



1b

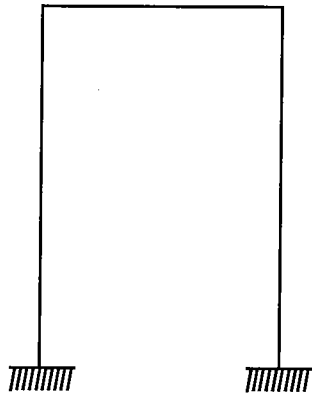

1c

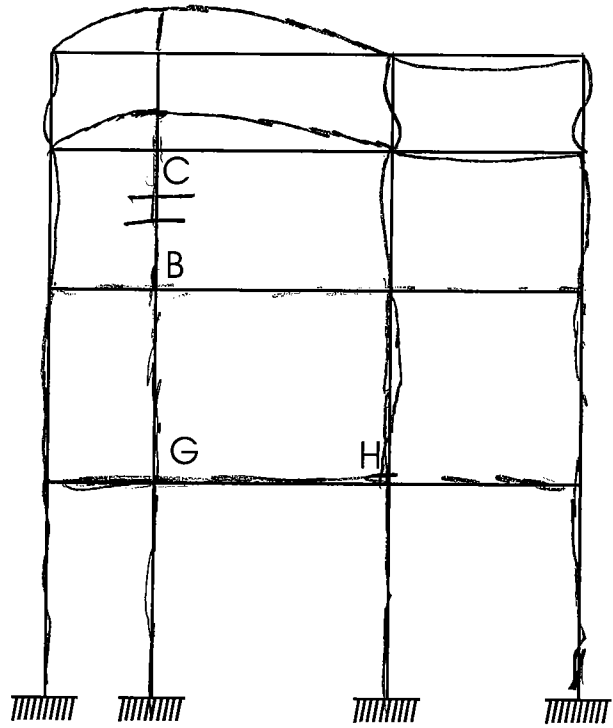

1d

Figure 1

PROB 9

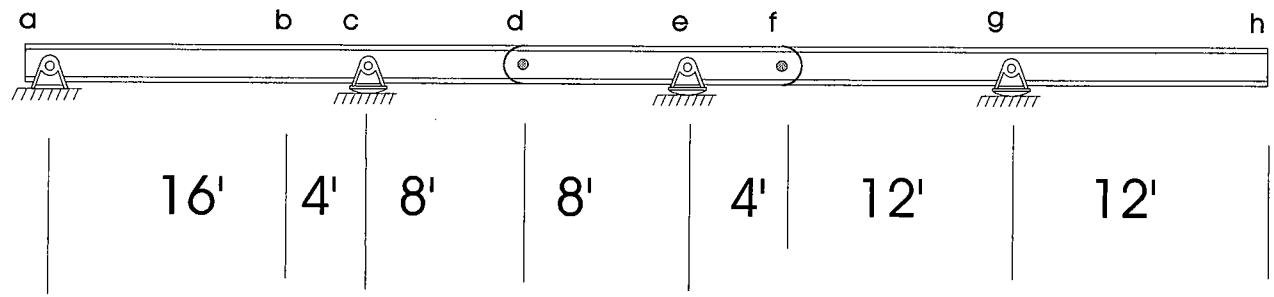

Figure 2

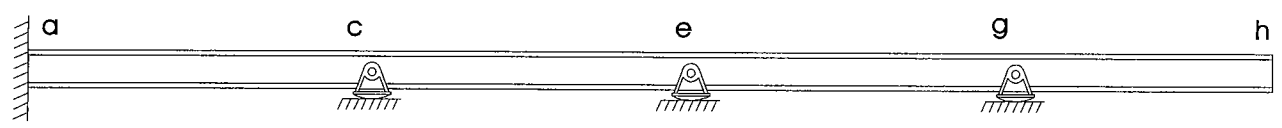

Figure 3

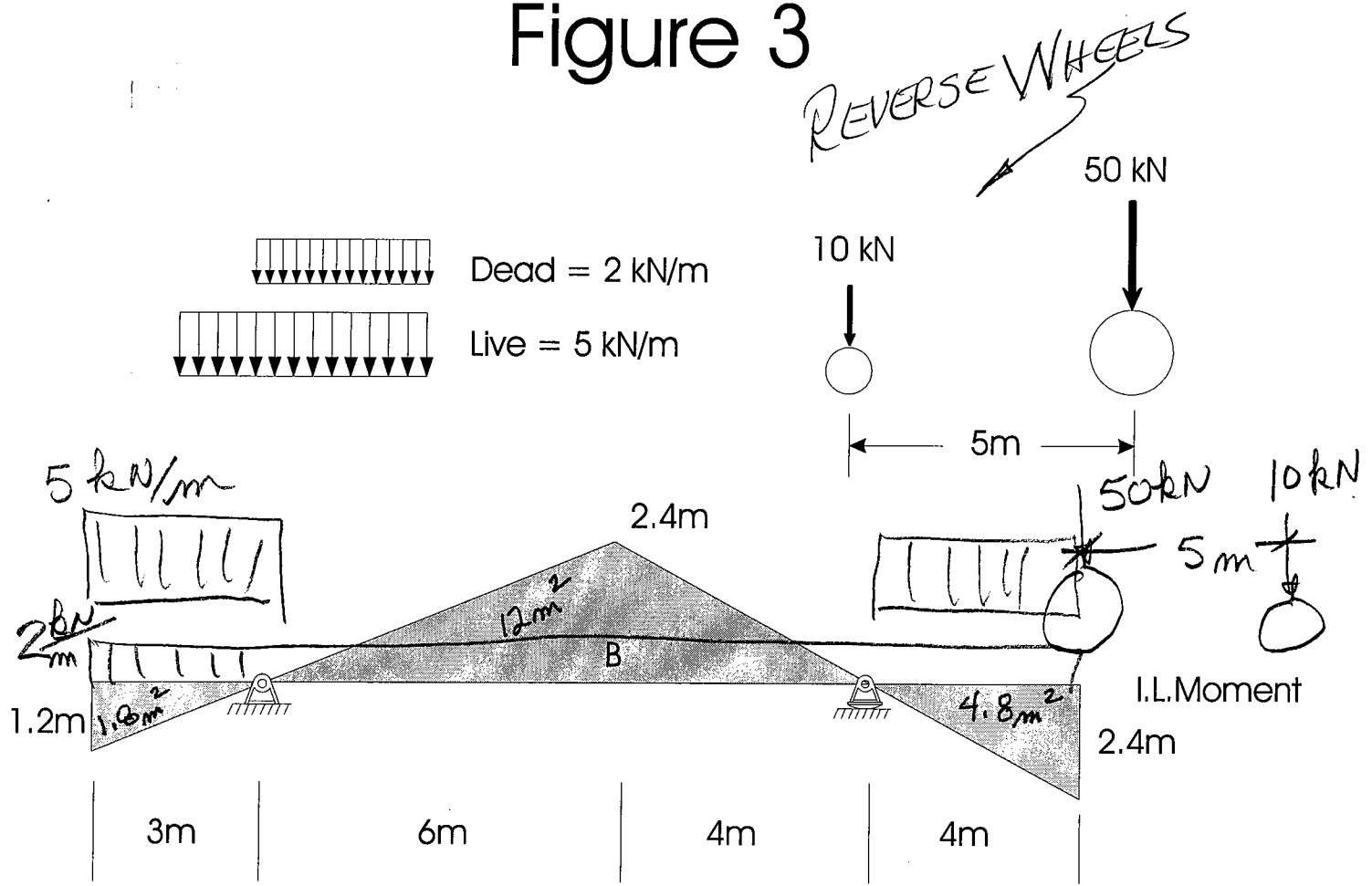

Figure 4

## PROB 9

$$M_D = \left\{ -(1.2\text{m})(3\text{m})\left(\frac{1}{2}\right) + (2.4\text{m})(10\text{m})\left(\frac{1}{2}\right) - (2.4\text{m})(4\text{m})\left(\frac{1}{2}\right) \right\} 2 \frac{\text{kN}}{\text{m}}$$
$$= +10.8$$

$$M_L = \left\{ -(1.2\text{m})(3\text{m})\left(\frac{1}{2}\right) - (2.4\text{m})(4\text{m})\left(\frac{1}{2}\right) \right\} 5 \frac{\text{kN}}{\text{m}}$$
$$= -33$$

$$M_{\text{TRUCK}} = -(2.4\text{m})(50\text{kN}) = -120$$

$$M_{\text{neg}} = +10.8 - 33 - 120$$
$$= -142.2 \text{ kNm}$$

PROB 10

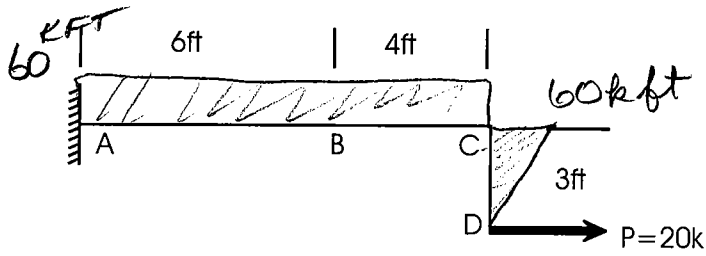

Figure 5

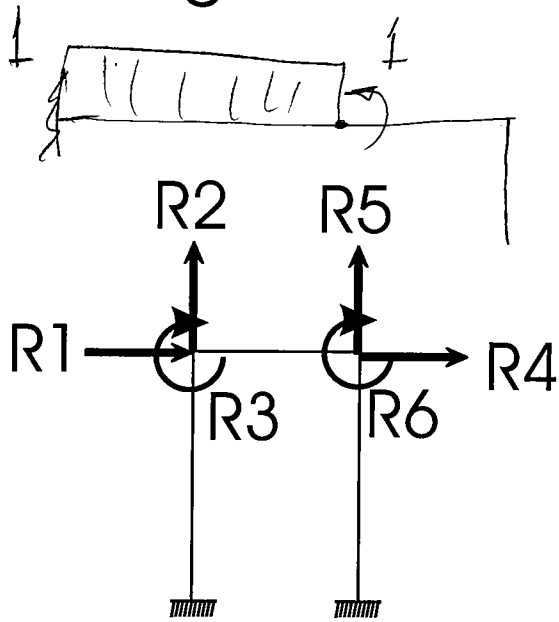

Figure 7

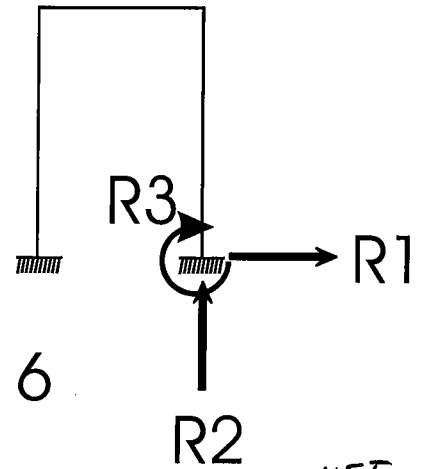

Figure 6

$$\Theta = \int \frac{M m dx}{EI} = \frac{60 \text{ kft} \cdot 1}{6 \text{ ft}} \cdot \frac{1}{6 \text{ ft}}$$

$$= L a c = \frac{(6 \text{ ft})(60 \text{ kft})(1)}{EI} = \frac{360}{EI}$$

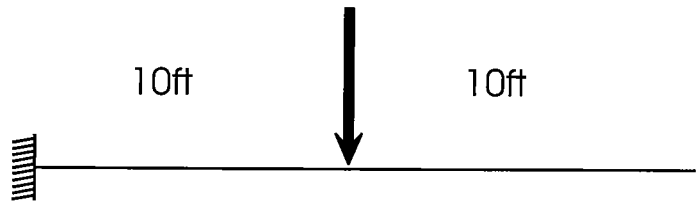

Figure 8

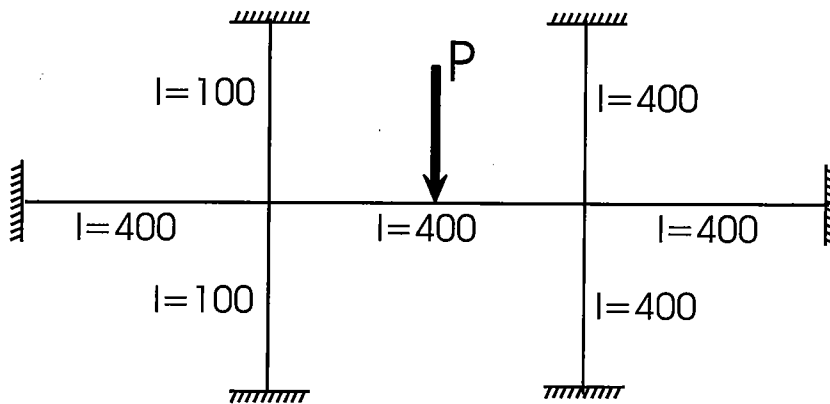

Figure 9

Prob 11

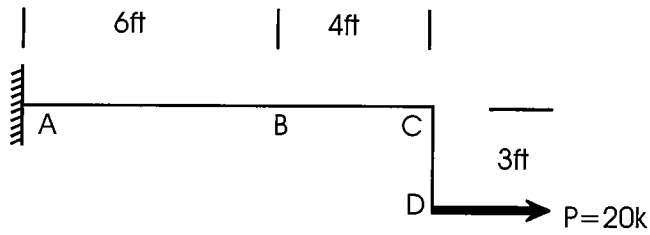

Figure 5

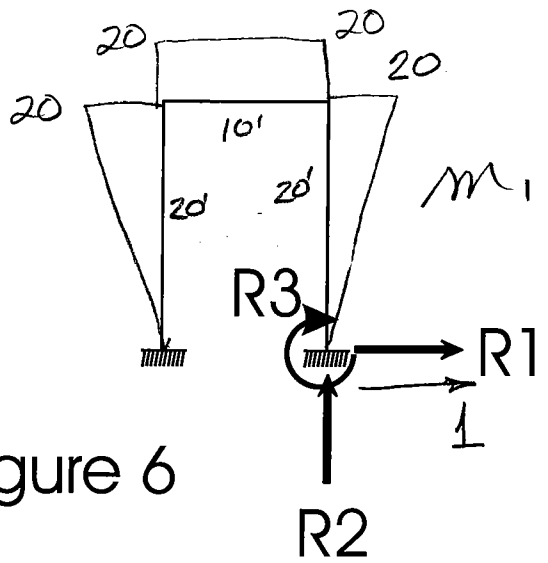

Figure 6

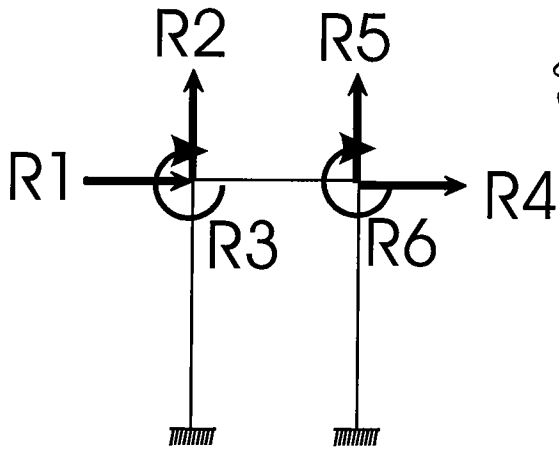

Figure 7

$$S_{11} = \int \frac{M^2}{EI} dy = \left\{ \frac{(20)(20)(20)}{3EI} \right\} 2 \text{ of them} + \frac{(20)(20)(10)}{EI} = \frac{9333}{EI}$$

Figure 8

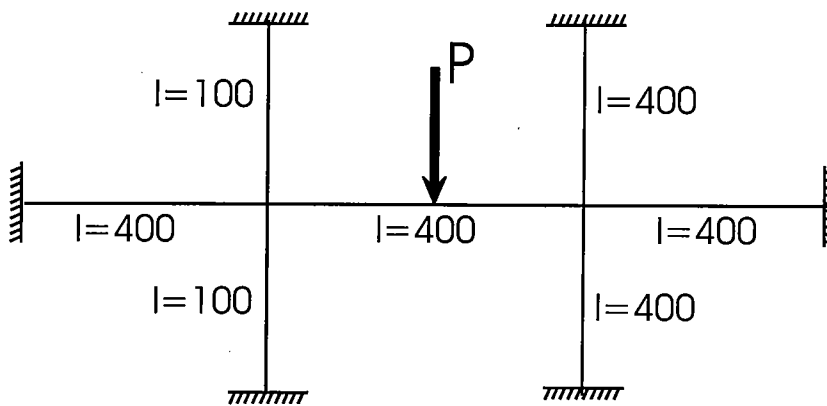

Figure 9

# PROB 12

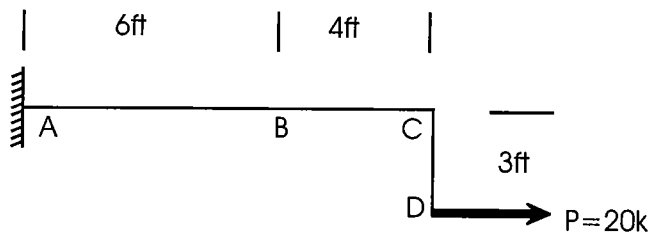

Figure 5

$$\Delta = \frac{PL}{AE}$$

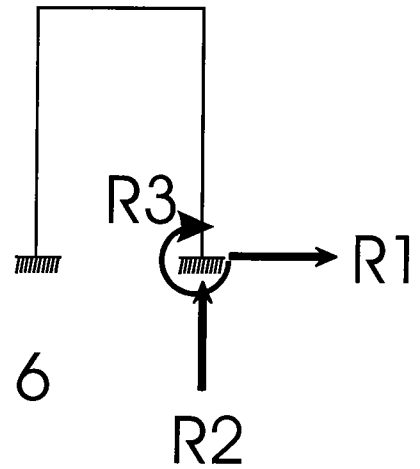

Figure 6

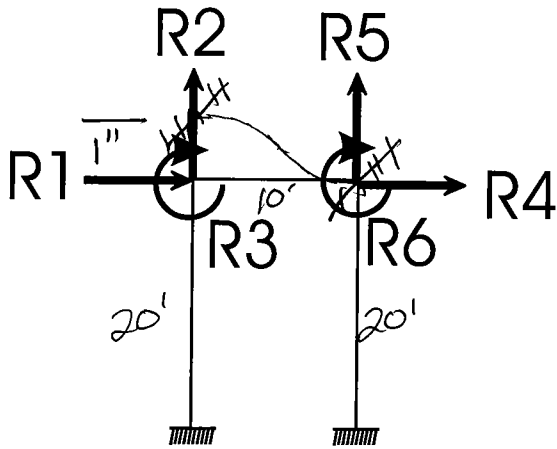
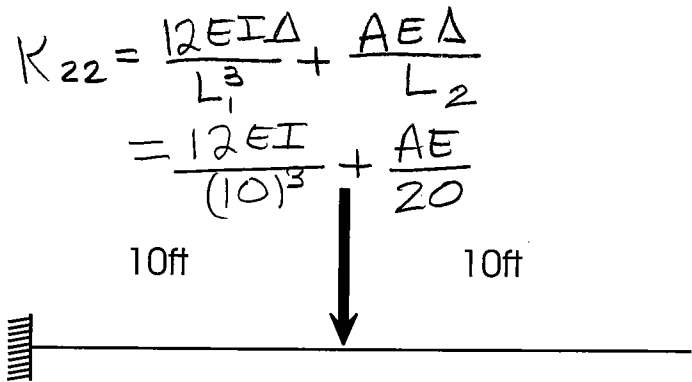

Figure 7



$$K_{22} = \frac{12EI\Delta}{L_1^3} + \frac{AE\Delta}{L_2}$$

$$= \frac{12EI}{(10)^3} + \frac{AE}{20}$$

Figure 8

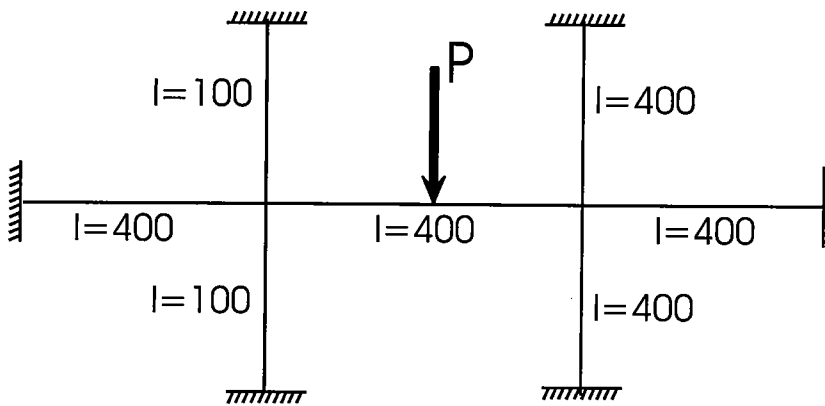

Figure 9

# PROB 13

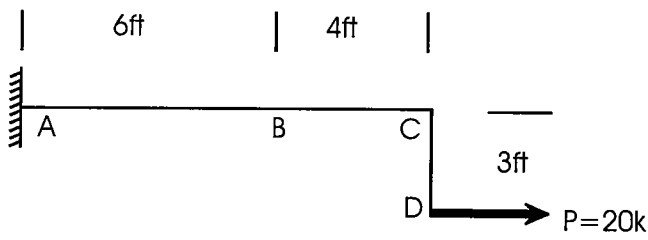

Figure 5

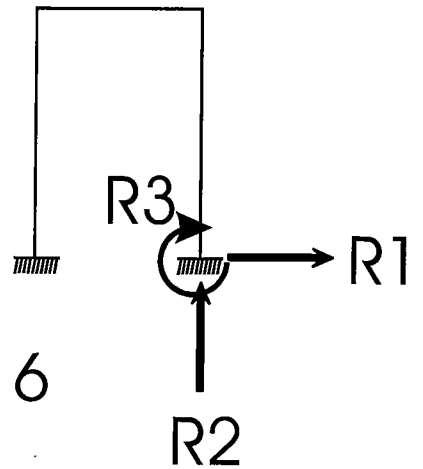

Figure 6

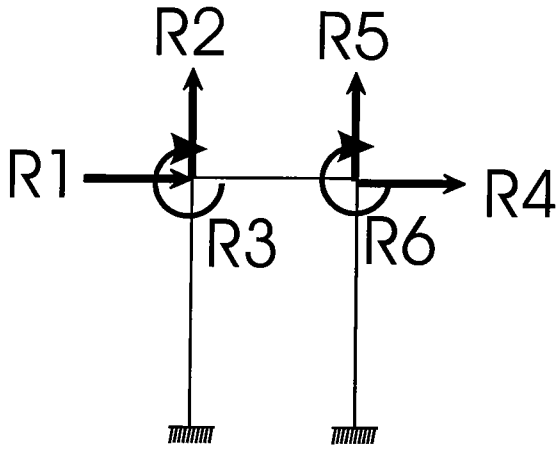

Figure 7

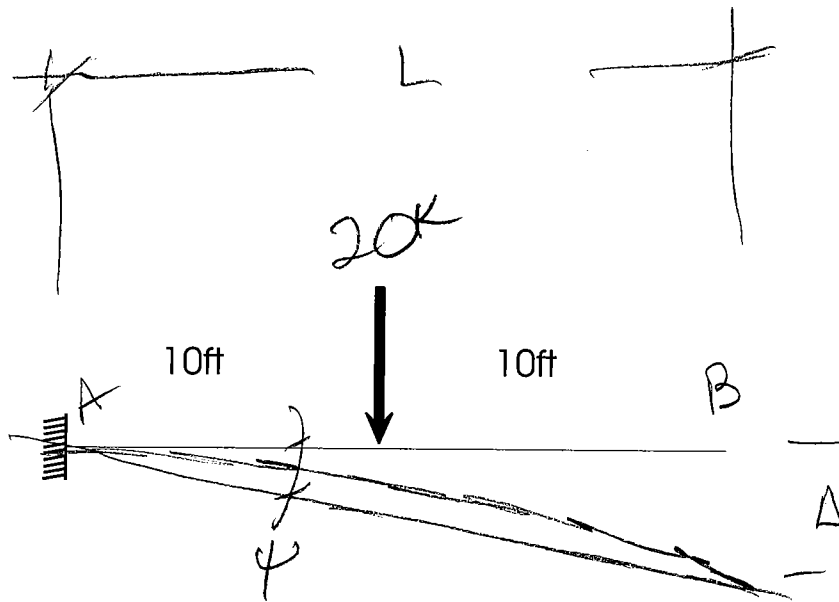
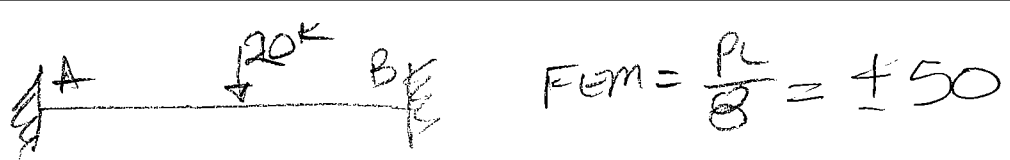

Figure 6



$$M_{AB} = \frac{2EI}{L}(2\theta_A + \theta_B - 3\psi) \pm FEM$$

$$\textcircled{1} M_{AB} = \frac{2EI}{L}\left(0 + \theta_B - \frac{3\Delta}{L}\right) - \frac{PL}{8} = -200 \text{ k ft}$$

$$\textcircled{2} M_{BA} = \frac{2EI}{L}\left(2\theta_B + 0 - \frac{3\Delta}{L}\right) + \frac{PL}{8} = 0$$

$$\textcircled{1} \frac{2EI\theta_B}{L=20\text{ft}} - \frac{6EI\Delta}{L^2=20^2} - \frac{20(20\text{ft})}{8} = -200 \text{ kft}$$

$$\textcircled{2} \frac{4EI\theta_B}{L=20} - \frac{6EI\Delta}{L^2=20^2} + \frac{20(20\text{ft})}{8} = 0$$

$$\left\{ \begin{array}{l} \textcircled{1} 0.1EI\theta_B - 0.015EI\Delta = -150 \\ \textcircled{2} 0.2EI\theta_B - 0.015EI\Delta = -50 \end{array} \right.$$

